

Hybrid LED 350w

9 PHOTOMETRIC DATA Beam spot wash 3-in-1

User Manual

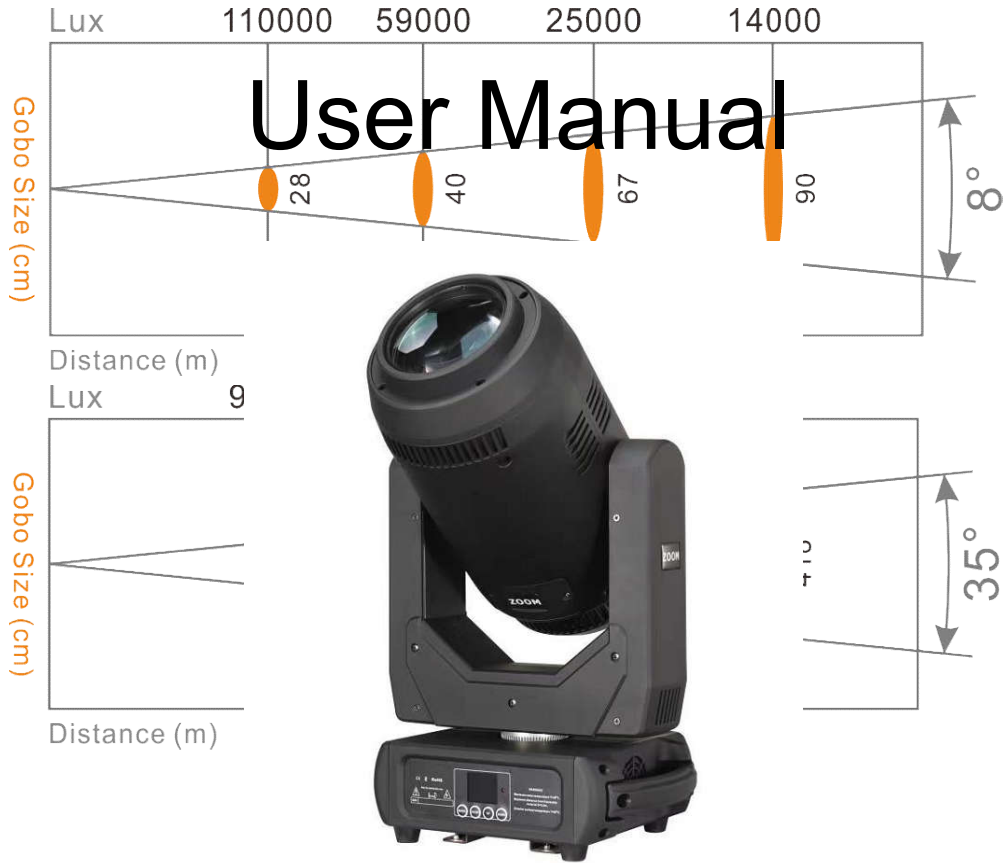

CE ∇ \oplus IP20 LED \sim 0.2m t_a 40°C t_c 150°C

Specifications

Input Voltage: AC90-260V 50/60Hz

Light Source: 350W High Output White LED

Control Signal: DMX 512, master-slave and sound activated or auto operation

Control Channel: 16/18 DMX Channels USITT DMX-512

Power Consumption: 450W

Dimensions: 312(L)*222(W)*590(H)mm

Packing size: 390(L)*310(W)*710(H)mm

Net Weight: 16kg, Gross Weight: 19kg

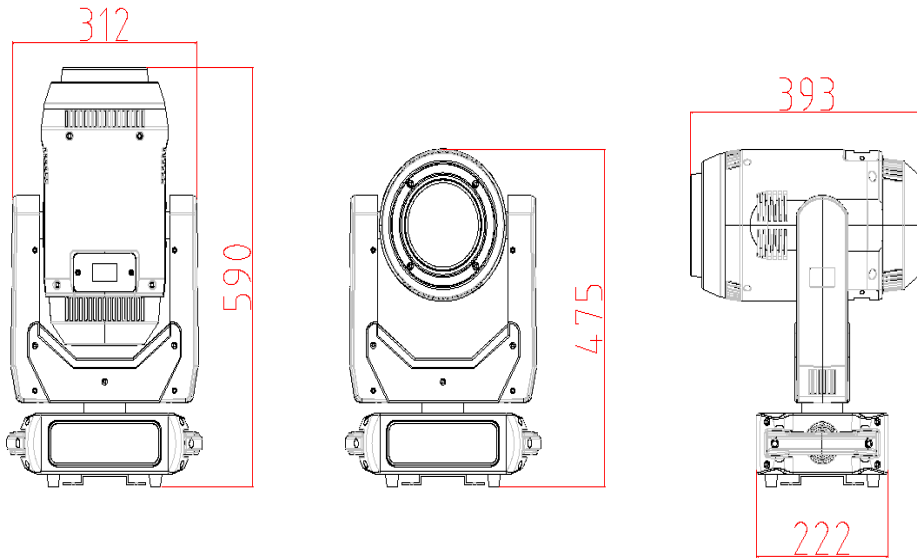

Note: This manual include important information on how to install and use it safely. Please read it carefully before install and operate as required. At the same time, please keep this manual properly for emergencies.

Contents

| | |
|-------------------------|----|
| 1. Safety warning | 3 |
| 2. User Instructions | 6 |
| 3. Lamp appearance | 8 |
| 4. Installation | 8 |
| 5. Function setting | 12 |
| 6. Menu operation | 14 |
| 7. DMX channel | 15 |
| 8. Technical parameters | 18 |
| 9. Photometric data | 20 |

Accessories:

The following random accessories have been packaged with light, please check and verify:



When this product leaves the factory, the performance is intact and the packaging is complete. All users should strictly abide by the warnings and operating instructions stated in this manual. Any damage caused by misuse is not covered by the company's warranty. Failures and problems caused by ignoring the operating manual are not within the scope of the dealer's responsibility.

This manual is subject to technical changes without notice.

Note: The company's products are calculated based on the company's delivery date.

| | | |
|--|---------|-----------|
| The warranty period of the whole machine is one year, and the light source is not within warranty. | 200-255 | Reset |
| | 254-255 | No action |

1 SAFETY INSTRUCTIONS

2 TECHNICAL PARAMETER

Notice
Please read the safety requirements in this section carefully before installing, energizing, operating or repairing!

High Output White LED
30,000 hours lifespan and low power consumption

The following important safety signs will be used in this product manual

- High light output, 25000LUX@5M at White light zoom in,
- 1500LUX@5M at White light zoom out



- Color Wheel: 7 colors + white, color fine tuning, rotation with variable direction and speed, with rainbow effect.

- After receiving the lamp, please unpack and check whether there is any damage caused by transportation. If there is damage caused by transportation, please do not use this lamp, and contact the dealer or manufacturer as soon as possible.
- Gobo Wheel: 7 gobos + white, wheel rotation and shake. The gobo plate is not allowed to be replaced or changed.
- The manufacturer will not be held responsible for the losses caused by not following this manual and changing the lamps at will.
- Prism: 8-facet Prism, bi-directional rotatable at variable speeds.

- Please note that the damage to the lamp caused by the modification of the lamp is not covered by the warranty.
- If you have any questions or suggestions, please contact the dealer or manufacturer in time.
- High speed strobe effect with 0.5-25 flashers per second
- Internal program available



- When the DMX512 use, it must be kept away from high temperature, fire, electric shock, vibration and strong light environment.



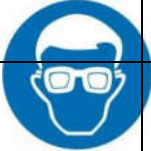

- Qualified operators can carry out installation, maintenance and repair, and ensure that they operate in strict accordance with the operating procedures of this manual

- There are no children who can be repaired by the user inside this lamp, please do not open the lamp to repair by yourself.

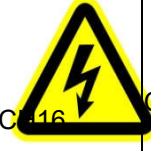
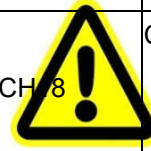
- Two 1/4 turn fastening Omega Clamps
- IP 20 protection rating

- Do not look directly at the light source of the lamp (especially for patients with epilepsy) to avoid damage to the eyes!
 - Do not connect this lamp to any other dimming device.
 - If visible damage occurs to the light source, lens or display protective cover on the lamp, it is damaged to the extent of failure. If cracks or deformation occur, please stop using it and contact the manufacturer to replace the original accessories, otherwise normal use will be affected.
 - The installation position of the luminaire should be such that it will not be stared at at a distance of less than 4 meters for a long time.
 - Before starting to operate the lamp, please check whether all the covers (or shells) have been installed and whether the screws have been tightened reliably. It is forbidden to use the lamp with the cover (or shell) open.
 - Keep the lamp clean and do not touch the lamp glass directly with your hands.
 - During operation, it is recommended to wear necessary protective equipment, such as goggles, gloves, etc.
-
- The person who connects the electrical part must have the corresponding qualifications before the operation.
 - Before installation, please make sure that the power supply voltage you are using matches the voltage marked on the lamp.
 - Each lamp should be properly grounded, and electrical installation should be carried out in accordance with relevant standards.
 - Do not use power cords with damaged insulation, and do not overlap power cords with other wires.
 - When the lamp is not in use or cleaning, please hold the power cord plug to unplug it, do not pull or directly pull the power cord.
 - Make sure that the power cord used complies with safety regulations.
 - If the lamp is not waterproof or dustproof, please be careful not to short-circuit the lamp when it is exposed to rain or moisture during the operation of the lamp.
 - Do not turn on or off the lamp repeatedly within a short period of time, as this will shorten the life of the lamp light source or other electrical components.
-
- There is a safety rope connection hole at the bottom of the lamp. For safety reasons, please pass the safety rope equipped with the lamp through the safety rope connection hole for auxiliary lifting.
 - Before any installation, maintenance and cleaning of the lamp, please make sure that the power supply has been cut off!

| | | | | | |
|---|--|------|----------------------|---------|--|
|  | CH12 | CH10 | Gobo Rotation | 128-191 | Gobo Rotate CW from slow to fast |
| | | | | 192-255 | Gobo Rotate CCW from slow to fast |
|  | CH13 | CH11 | Focus | 0-15 | open |
| | | | | 16-95 | Gobo Rotation 0-250 |
| | | | | 96-135 | Gobo Rotating 0-90 |
| | | | | 136-155 | Gobo Rotating 0-300 |
| | | | | 156-175 | Gobo Rotating 0-360 |
| | | | | 176-215 | Gobo self-rotating CW from slow to fast |
| | | | | 216-255 | Gobo self-rotating CCW rotating from slow to fast |
| | CH14 | CH12 | ZOOM | 0-255 | Angle from narrow to wider |
|  | CH15 | CH13 | Prism Rotation | 0-63 | Open |
| | | | | 64-255 | Prism In |
| | | | | 0-15 | open |
| | | | | 16-95 | Prism Rotation 0-250 |
| | | | | 96-135 | Prism Rotating 0-90 |
| | | | | 136-155 | Prism Rotating 0-250 |
| | | | | 156-175 | Prism Rotating 0-360 |
| 176-215 | Prism self-rotating CW from slow to fast | | | | |
| | | | | 216-255 | Prism self-rotating CCW rotating from slow to fast |
| | CH17 | CH15 | Frost | 0-63 | Open |
| | | | | 64-255 | Frost |
|  | CH18 | CH16 | self-setting Program | 0-7 | No action |
| | | | | 8-131 | Auto mode |
| | | | | 132-249 | Soud mode |

| | | | | | |
|--|-----------------------------------|-------------------------|---------|----------------------------------|--|
|    | CH8 | Static gobo wheel | 0-6 | open | |
| | | | 7-13 | Gobo1 | |
| | | | 14-20 | Gobo2 | |
| | | | 21-27 | Gobo3 | |
| | | | 28-34 | Gobo4 | |
| | | | 35-41 | Gobo5 | |
| | | | 42-48 | Gobo6 | |
| | | | 49-55 | Gobo7 | |
| | | | 56-63 | Gobo 8 | |
| | | | 64-70 | Gobo 8 shake | |
| | | | 71-77 | Gobo 7 shake | |
| | | | 78-84 | Gobo 6 shake | |
| | | | 85-91 | Gobo 5 shake | |
| | | | 92-98 | Gobo 4 shake | |
| | | | 99-105 | Gobo 3 shake | |
| | | | 106-112 | Gobo 2 shake | |
| | | | 113-119 | Gobo 1 shake | |
| | | | 120-127 | open |  |
| | | | 128-191 | Gobo rotate CW from slow to fast | |
| 192-255 | Gobo rotate CCW from slow to fast | | | | |
| CH11 | CH9 | 7 rotation gobos +White | 0-15 | open | |
| | | | 16-31 | Gobo1 | |
| | | | 32-47 | Gobo2 | |
| | | | 48-63 | Gobo3 | |
| | | | 64-79 | Gobo4 | |
| | | | 80-95 | Gobo5 | |
| | | | 96-111 | Gobo6 | |
| | | | 112-127 | Gobo7 | |

- Under normal working conditions at room temperature, the temperature of the outer metal surface of the lamp (including the surface of the radiator) will reach 50°C at the highest temperature.
- There will be smoke and peculiar smell before the light is turned on for the first time. This is a normal process and does not mean that the lamp is defective.
- When using, do not touch the shell with bare hands to avoid burns!
- Please do not install the lamp directly on the surface of ordinary combustible materials.
- Do not project the lamp directly on combustible objects, and the distance between the lamp and the illuminated object is more than 10 meters.
- The lamp should be installed in a well-ventilated place, and the distance from the wall should be kept at least 50 cm. At the same time, please check whether the fan and ventilation holes are unblocked.
- Please do not expose the front glass to sunlight or other strong light sources from any angle. The lens may focus the light in the lamp, which may cause a potential fire hazard.
- This product complies with the "General Technical Requirements Standards for the Recycling of Waste Electrical and Electronic Products"
- When the product reaches the scrap standard and needs to be scrapped, the customer can scrap and recycle the product.

2 USER INSTRUCTIONS

Cleaning and Maintenance

When the lamp cannot be started, please check whether the power fuse of the lamp is blown. The lamp is equipped with an overheating protection device. The protection device will automatically cut off the power when it is overheated. When this happens, please check whether the fan is running normally and whether the fan and fan net are blocked by dust. Find out the fault and repair it before starting the lamp.

Because substances such as smoke oil and dust tend to adhere to the lens and reduce the light output, in order to ensure the reliable use of the lamp, it is very necessary to keep the lamp clean. The cooling fan should be cleaned every 15 days. The cleaning of internal and external optical lenses, mirrors, and coated color filters must be performed periodically to optimize light output.

The cleaning frequency depends on the operating frequency of the lamp and the surrounding environment. When cleaning, use a soft cloth and general glass cleaning products to clean. It is recommended to clean the external optical system at least once every 20 days, and clean the internal optical system at least once every 30/60 days. Keep the lens clean and do not directly touch the optics of the lamp with your hands.

- Before performing any maintenance and cleaning the lamp, please make sure that the power has been cut off!
- Only qualified technicians can carry out maintenance work.
- Before maintenance, the power must be completely cut off!

- In order to prevent sunlight or other light from directly irradiating the head lens and focusing on the inside of the lamp body to cause high temperature damage to the lamp, before the lamp is powered off,

7 DMX CHANNEL

18/16 channel mode sheet

| 18CH | 16CH | Function | Channel Value | Description |
|------|------|-----------------|---------------|-------------------------------|
| CH1 | CH1 | Pan | 0-255 | 0-540° |
| CH2 | | Pan fine | 0-255 | Pan Fine |
| CH3 | CH2 | Tilt | 0-255 | 0-270° |
| CH4 | | Tilt Fine | 0-255 | Tilt Fine |
| CH5 | CH3 | X, Y speed | 0-255 | From fast to slow |
| CH6 | CH4 | LED Dimmer | 0-255 | From dark to bright |
| CH7 | CH5 | LED Strobe | 0-7 | Turn on |
| | | | 8-300 | Strobe from slow to fast |
| | | | 251-255 | Turn on |
| CH8 | CH6 | 7 color + White | 0-15 | White Lighting |
| | | | 16-31 | Color 1 |
| | | | 32-47 | Color 2 |
| | | | 48-63 | Color 3 |
| | | | 64-79 | Color 4 |
| | | | 80-95 | Color 5 |
| | | | 96-111 | Color 6 |
| | | | 112-127 | Color 7 |
| | | | 128-191 | CW from slow to fast |
| | | | 192-255 | CCW from slow to fast |
| CH9 | CH7 | Color effect | 0-10 | No function |
| | | | 11-209 | Color fine tuning |
| | | | 210-255 | Color shake from fast to slow |

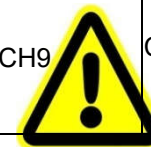
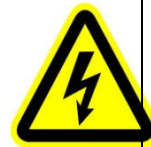

6

MENU OPERATIONS

MENU

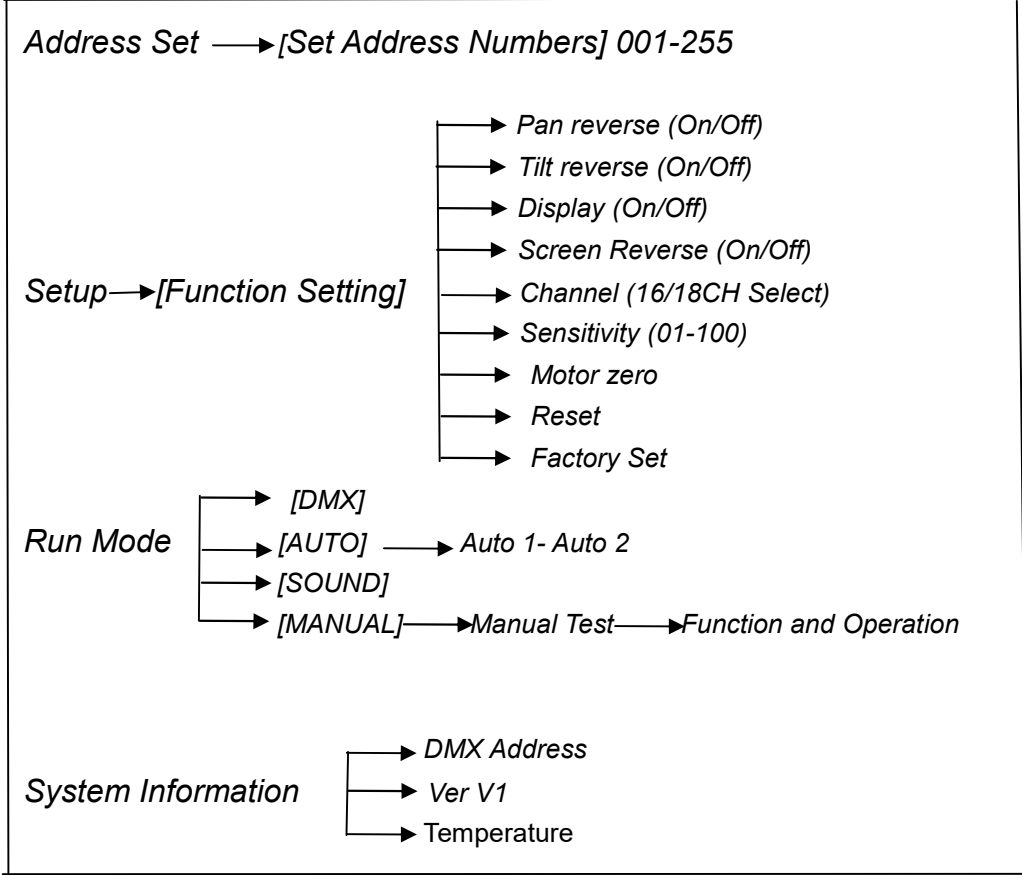

please use the Y-axis control channel to keep the lamp head down.

- Do not wipe the lamp housing with organic solvents such as alcohol to avoid damage.
- Do not use any solvents containing chemical components to clean the coated color filters.

• Lubrication

In order to maintain the smooth rotation of the gobo and the smooth movement of the focus lens, it is recommended to give the focus lens every two months

The 3 guide rails and the 2 guide rails of the magnifying lens are lubricated once. Good and high-temperature-resistant lubricating oil/grease should be used.

• Ordinary Troubleshooting

| Fault description | Take countermeasures |
|--|---|
| The lamp can't work normally | check if the power fuse is blown Check if the bulb is in good condition |
| The lamps are not controlled by the controller | Check if the DMX start address of the lamp is set correctly Check if the XLR signal cable is damaged |
| The lamps work intermittently | Check whether the fan is working normally, and whether dust is blocking the fan and the fan net |
| The light is dim and the brightness is obviously reduced | Check whether the LED light source has reached the expiration date Check whether the internal and external optical system is clean |
| The beam is impure (has a halo) | Clean the dust and oil from the lens and other parts |
| Serious beam distortion | Check if the lens is broken Clean the lens dust or oil |

● **Stand-alone mode**

Do not connect the controller and the control line. When the automatic program of the host mode of the lamp is set to be valid, the lamp will run in the stand-alone mode.

● **Master/Slave synchronization mode**

If you need to connect multiple lamps to the master/slave synchronization mode, first connect the XLR-XLR control line from the DMX output port of the first lamp to the DMX input port of the second lamp, and from the DMX output port of the second lamp connect to the DMX input port of the third lamp, and so on, until all lamps are connected, and then plug the loop into the signal output port of the last lamp to complete the connection. Then the first lamp is the master, and the other lamps are the slaves.

Set the address code of the slave to 001; the operating mode of the master is set to any one of the operating modes of the master, and the operating mode of the slave is set to the slave operating mode corresponding to the operation of the master.

After power on, the fixture group runs in master/slave synchronization mode.

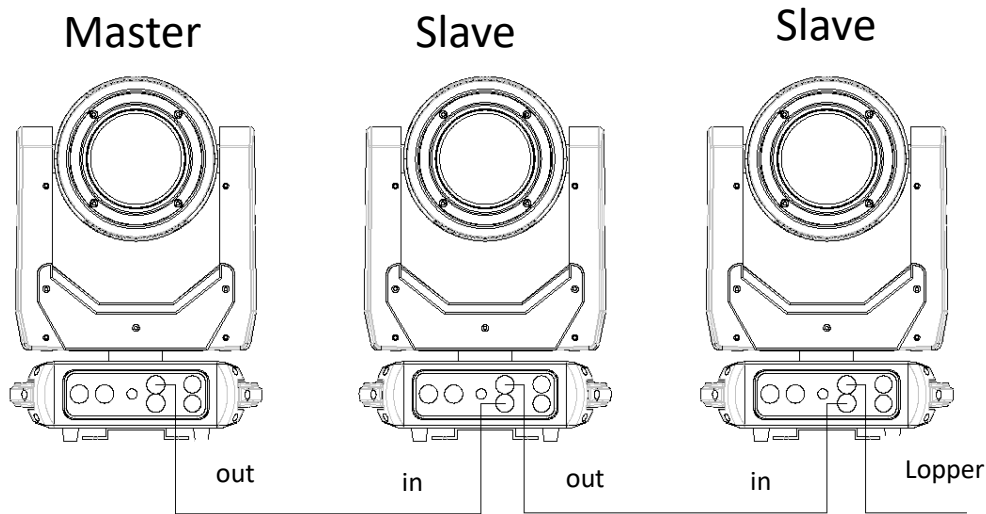

3

LAMP APPEARANCE



4

INSTALLATION

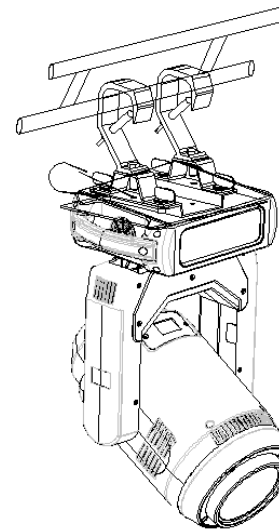

Warning!!

To ensure safety, please pass the safety rope through the connection hole to ensure safety.

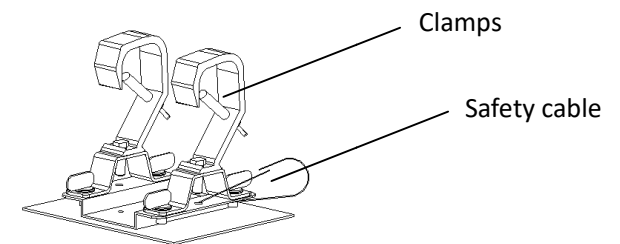

To view or modify the function settings of the lamp, press any key (in the power-on state) to light up the screen, and then press the UP and DOWN keys to enter the corresponding menu of the lamp. There are corresponding sub-menus in the function operation main menu, and each menu represents a specific function of the lamp. For details, see the sixth point "Operation Menu" below.

1. In the lamp function menu setting page, press the UP and DOWN keys to select the corresponding function.



When operating the menu, the MENU button is the menu button, and the ENTER button is the confirmation button. Press the ENTER button to save your changes or exit the submenu. Press the UP or DOWN button to modify the value (increase or decrease the value).

Press the MENU button to return to the previous menu. If you don't press it, the system will automatically return to the display state.

● Lamp DMX start address setting

When using a controller to control multiple lamps, each lamp must be set with a DMX start address to receive the signal from the controller and respond correctly. This product has 2 control modes, namely standard mode and simplified mode. Take the standard mode as an example: the product has 18 channels, the DMX start address of the first lamp is set to 001, the second is 019, the third is 037, and so on, and so on.

Turn on the lamp, after the initialization of the lamp is completed, press any key to light up the operation panel, and then press the UP or DOWN key to enter the corresponding operation menu of the lamp

Select the "DMX setting" icon and press the ENTER key or click directly on the screen, and select DMX address setting in the secondary menu;

Press the UP and DOWN keys to get the set value;

Then press ENTER to confirm,

Press the MENU button to return to the previous menu.

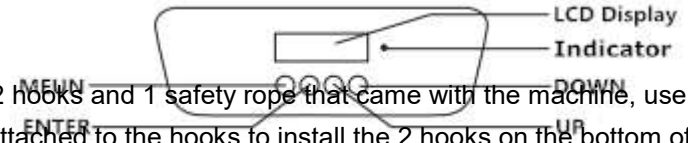

Take out the 2 hooks and 1 safety rope that came with the machine, use the 4 hook quick knobs attached to the hooks to install the 2 hooks on the bottom of the luminaire, and then hang the luminaire on the fixed bracket with the hooks and twist Tighten the hook and lock bolts to fix the whole lamp. Please confirm that the lamp is installed firmly and reliably, and ensure that the hoisting position has enough strength to bear the weight of the lamp. For safety reasons, please follow the warning shown in the figure above to pass the safety rope provided with the lamp through the safety hole at the bottom of the lamp holder for auxiliary lifting to ensure safety.

Warning!!

- The hook is only used when hoisting the lamp. It is strictly forbidden to use the hook as a handle to carry the lamp. Please use the handle when carrying.

- For safety reasons, please use a safety rope that can withstand 10 times the weight of the lamp to pass through the safety hole of the lamp for auxiliary lifting.

● Power connection:

The power cord connection is as follows:

L (fire wire) = brown wire

E (ground wire) = yellow/green two-color wire

N (center line) = blue line

When connecting the power supply, please note that the power supply voltage and frequency must be consistent with the voltage and frequency marked on the nameplate of the lamp. When multiple lamps are used at the same time, it is recommended to connect the power supply of each lamp separately, so that each lamp can be individually controlled on/off.

- When connecting the power supply, the ground wire (yellow/green two-color wire) must be safely grounded, and the electrical installation

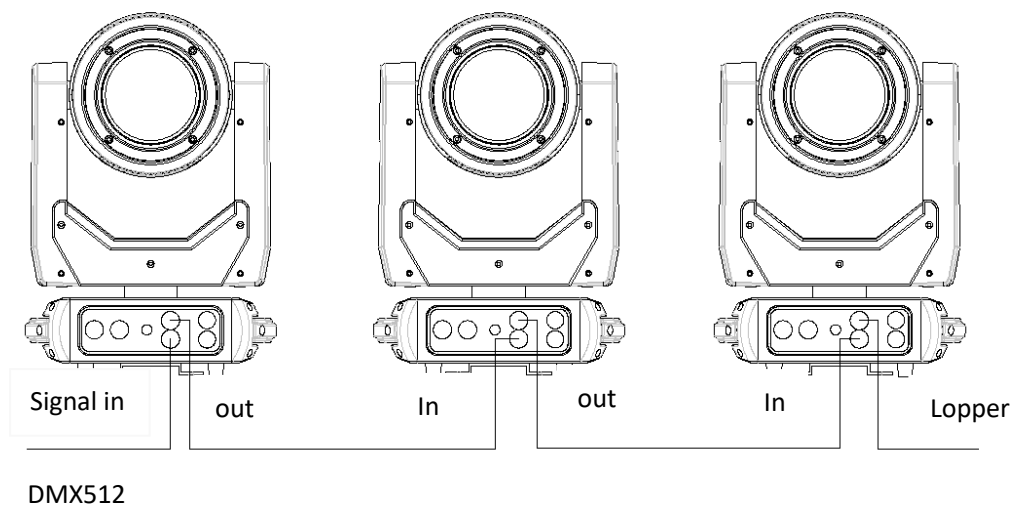

DMX loop plug

In the "controller mode", the DMX output port of the last lamp must be connected to the DMX loop plug. This circuit is inserted between pin 2 and pin 3 of the "Canon" plug and connected with a resistance of about 120 Ω (OHM) (as shown in the figure below). Plug this loop into the output port of the last lamp, which can effectively avoid the noise and reflection caused by the DMX512 signal during the transmission process.

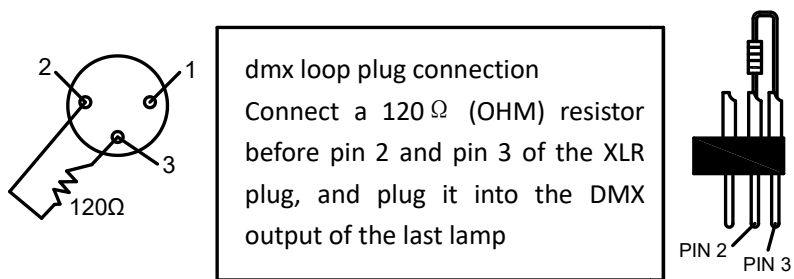

5 FUNCTION SETTING

•Display operation

must comply with all relevant standards.

● If you have any questions about electrical installation, please do not operate and consult a qualified electrician.

● Connection of control signal:

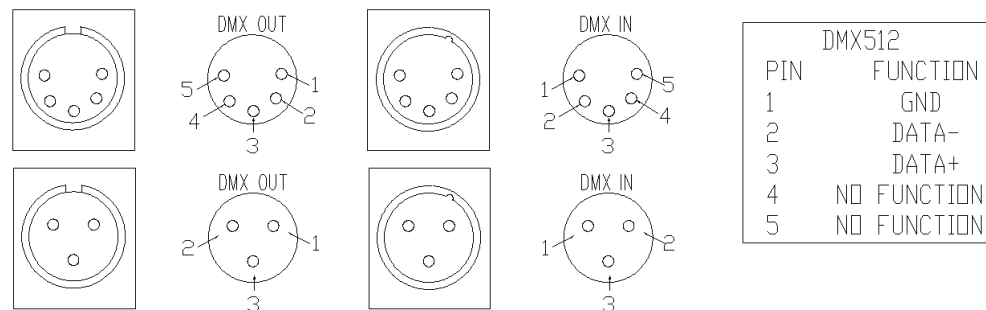

The connection between the lamp and the controller and between the lamp and the lamp must use a two-core shielded wire with a diameter of not less than 0.5 mm. Please use a 3-pin (included) XLR plug/seat to connect the DMX512 output/inlet of the lamp. The connection between the XLR plug/socket and the wire is shown in the list above. It must be noted that the 3-core of the XLR plug/seat cannot be in contact with the inner shell and the core and the core cannot be in contact during the connection. Except for the connection methods shown in the list above, the XLR plug/seat and the XLR control line cannot be connected in any other way. This product receives the international standard DMX512 (1990) control signal.

Use the XLR-XLR control cable to connect the DMX output port of the controller to the DMX input port of the first slave, and connect the DMX output port of the first slave to the DMX input port of the second slave, and so on By analogy, until all the slaves are connected, and finally the circuit is connected to the signal output port of the last lamp to complete the controller mode connection. As shown below: