

## LED MOVING HEAD

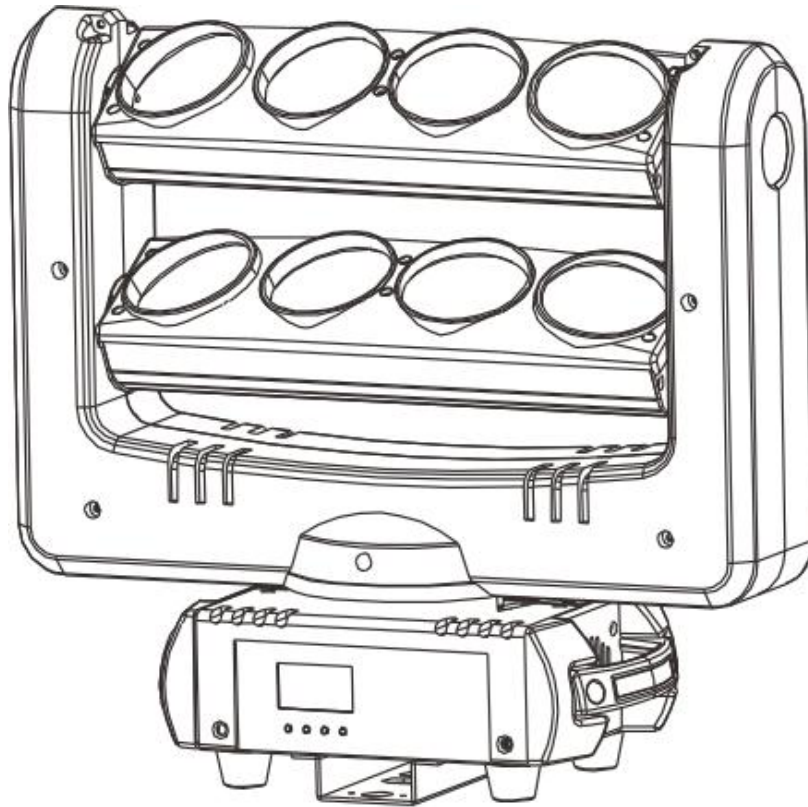

## FLEX BEAM K8 RGBW

### **User Manual**

Please read the instruction carefully before use

## CONTENTS

1. Safety Instructions .....	3
2. Technical Specifications .....	4
3. How To Set The Unit.....	5
3.1 Front & Rear Panel.....	5
3.2 Main Function.....	6
4. How to Control the Unit.....	9
4.1 Master/Slave Built In Preprogrammed Function.....	9
4.2 DMX Address Setting .....	9
5. DMX512 Configuration .....	10
6. DMX Connection .....	11
7. Troubleshooting.....	12
8. Fixture Cleaning .....	13

## 1. Safety Instructions



### WARNING

Please read the instructions carefully which includes important information about the installation, operation and maintenance.

- PLEASE keep this User Manual for future consultation. If you sell the fixture to another user, make sure that they also receive this instruction booklet.
- PLEASE unpack and check carefully there is no transportation damage before using the fixture.
- It's important to ground the yellow/green conductor to earth in order to avoid electric shock.
- PLEASE disconnect main power before servicing and maintenance.
- Maximum ambient temperature is  $T_a: 40^{\circ}\text{C}$ . DO NOT operate it where the temperature is higher than this.
- Unit's surface temperature may reach up to  $85^{\circ}\text{C}$ . DO NOT touch the housing bare-handed during its operation.
- In the event of serious operating problem, stop using the fixture immediately. Never try to repair the fixture by yourself. Repairs carried out by unskilled people can lead to damage or malfunction. Please contact the nearest authorized technical assistance center. Always use the same type spare parts.
- DO NOT connect the device to any dimmer pack.
- DO NOT touch any wire during operation and there might be a hazard of electric shock.
- The housing must be replaced if they are visibly damaged.

### Warning

- To prevent or reduce the risk of electrical shock or fire, do not expose the unit to rain or moisture.
- DO NOT open the unit within five minutes after switching off.
- The housing, the lenses, or the ultraviolet filter must be replaced if they are visibly damaged.

For 230V 50Hz power supply, maximum fixtures that can be connected together from the same mains outlet is 7pcs;  
For 120V 60Hz power supply, maximum fixtures that can be connected together from the same mains outlet is 4pcs;

## Caution:

There are no user serviceable parts inside the unit. DO NOT open the housing or attempt any repairs yourself. In the unlikely event your unit may require service, please contact your nearest dealer.

## Installation:

The unit should be mounted via its screw holes on the bracket. Always ensure that the unit is firmly fixed to avoid vibration and slipping while operating. And make sure that the structure to which you are attaching the unit is secure and is able to support a weight of 10 times of the unit's weight. Also always use a safety cable that can hold 12 times of the weight of the unit when installing the fixture.

The equipment must be fixed by professionals. And it must be fixed at a place where is out of the touch of people and has no one pass by or under it.

## 2. Technical Specifications

- Innovative moving heads, delivering marvelous, laser-like and long-throw multi-beam effects
- Moving pan with 2 movable LED bars, each with 4 pixel controlled 10W LEDs for the best mid-air lighting effects
- 3 Operation Modes: DMX, Master/Slave mode, Sound Activation.
- DMX Channel modes: 11 and 37 channels
- Great built-in programs under master/slave operation triggered by music.
- Smooth dimming and various strobe effects.
- Punch powerful beams, covering whole venue, perfect for events, discos, bars, Mobile DJs and more.
- **Power Voltage:** AC 100~240V, 50/60Hz
- **Power Consumption:** 90W
- **LED Sources:** 8 x 10W RGBW Cree LEDs
- **Weight:** 7.8kgs

- **Dimension:** 405 x 148 x 381mm

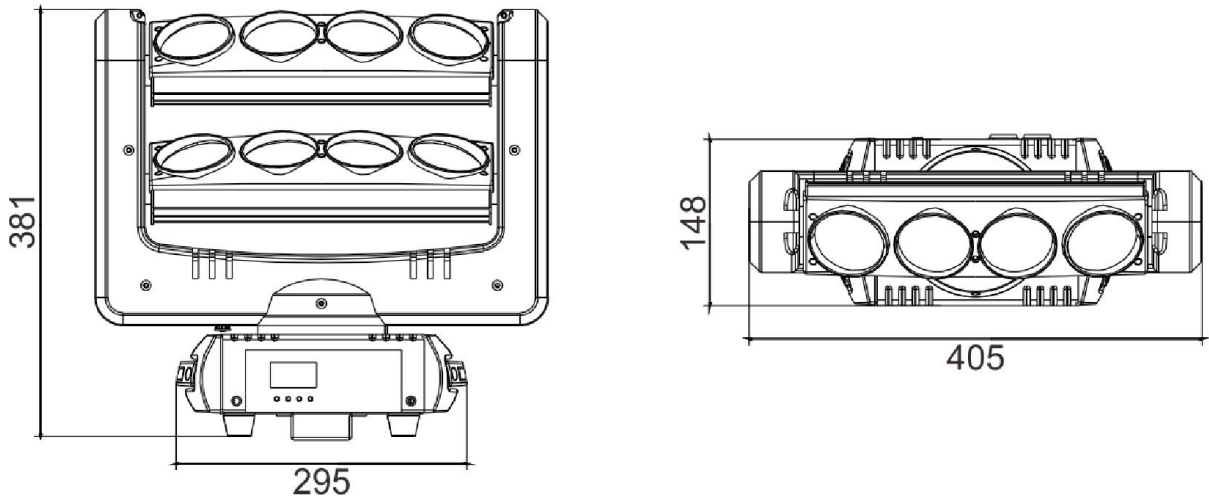

### 3. How To Set The Unit

#### 3.1 Front & Rear Panel

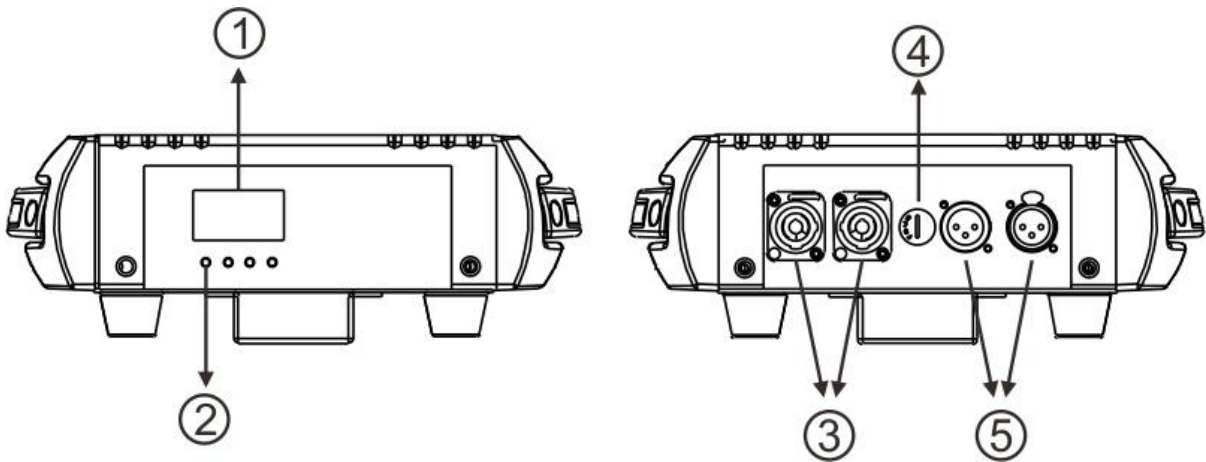

**1. Function Display:** Used to show the various menus and the selected functions.

**2. Button:**

<b>FUNCTION</b>	To return to the upper menu one by one
<b>DOWN</b>	To go backward in the selected functions
<b>UP</b>	To go forward in the selected functions
<b>ENTER</b>	To confirm the selected functions

**3. POWER IN/OUT:** Used to connect to supply power;

**4. Fuse (T 3.15A):** Used to protect the unit from the damage of over-current;

**5. DMX IN/OUT:** For DMX512 links, use 3-pin XLR plug cable to link the unit together;

### **3.2 Main Function**

To select any functions, press the **ENTER** button until the required function is showing on the display. Select the function by pressing the **ENTER** button. Use the **DOWN** and **UP** button to change the mode. Once the required mode has been selected, press the **ENTER** button to setup to go back to the functions without any changes press the **FUNCTION** button. Press the **FUNCTION** button to exit the menu mode.

NO	Display	Functions
1	DMX Address	A001 - A512 Address
2	Channel Mode	11CH, 37CH Channel mode select
3	Show Mode	SOUND AUTO, effect select
4	Slave Mode	Select: MAST, SL 1, SL 2,
5	Black Out	YES, NO standby mode
6	Sound State	ON, OFF
7	Sound Sense	(0-100)
8	Pan Inverse	YES, NO
9	Back Light	ON, OFF
10	Auto Test	Auto Test
11	Fixture Time	0 - 9999
12	Software Version	V104

13	Defaults	YES, NO
14	System Reset	YES, NO

Note:

There is only one Projector to be set as a Master in a signal Cable. If Master's functions used, Please disable DMX control signal.

When multiple projectors' work together in synchronous control state, Parameters can be transmitted from the master projector to the slave projectors such as DMX channel mode, Display setting status and operation mode (User memory data is included). Before parameters transmitted, the projector which will send parameters should be set as a Master and others be as Slaves.

## 4. How to Control the Unit

You can operate the unit in three ways:

1. By master/slave built-in preprogram function
2. By DMX controller

No need to turn the unit off when you change the DMX address, as new DMX address setting will be affected at once. Each time you turn the unit on, it will show "BEAM-K8" on the display. After that the unit will be ready to receive DMX signal or run the built in programs.

### 4.1 Master/Slave Built In Preprogrammed Function

By linking the units together in master/slave, the first unit (the master) will control the other units (the slave) to give an automatic, sound activated, synchronized light show. This function is good when you want an instant show.

To set the first unit as a master, press the **ENTER** button to show the **MASTER MODE** on the display.

To set the unit as a slave, press the **ENTER** button to show **SLAVE MODE** on the display.

### 4.2 DMX Address Setting

To set the DMX address, press the **MENU** button to show **DMX Address** on the display. Press the **ENTER** button. Use the **DOWN** and **UP** button to change the DMX address. Once the address has been selected, press the **ENTER** button to setup, to go back to the functions without any change

press the **FUNCTION** button. Press the **FUNCTION** button to exit the menu mode.

Please refer to the following diagram to address your DMX512 channel for the first 4 units.

Channel Mode	Unit 1	Unit 2	Unit 3	Unit 4
11 channel	1	12	23	34
37 channels	1	38	75	112

Figure 10-1

## 5. DMX512 Configuration

11CH Mode( 11 Channels )					
Number	Channel	DMX Value			Description
1	Pan	0	-	255	Pan 0 to 540 degree
2	Tilt 1	0	-	127	Tilt from 0-360 degree
		128		191	CW Infinity tilt Fast-Slow
		192		255	CCW infinity tilt slow-fast
3	Tilt 2	0	-	127	Tilt from 0-360 degree
		128		191	CW Infinity tilt Fast-Slow
		192		255	CCW infinity tilt slow-fast
4	Dimmer All	0	-	255	All dimmer 0 to 100%
5	Strobe	0	-	9	Blackout
		10	-	250	Strobe from slow to fast
		251	-	255	Open
6	Red	0	-	255	Red Dimming 0-100%
7	Green	0	-	255	Green Dimming 0-100%
8	Blue	0	-	255	Blue Dimming 0-100%
9	White	0	-	255	White Dimming 0-100%
10	Led chase	0	-	7	Blackout
		8	-	22	Chase 1
		23	-	37	Chase 2
		38	-	52	Chase 3
		53	-	67	Chase 4
		68	-	82	Chase 5
		83	-	97	Chase 6
		98	-	112	Chase 7
		113	-	127	Chase 8
		128	-	142	Chase 9



		143	-	157	Chase 10
		158	-	172	Chase 11
		173	-	187	Chase 12
		188	-	202	Chase 13
		203	-	217	Chase 14
		218	-	232	Chase 15
		233	-	247	Chase 16
		248	-	255	Full on
11	Chase speed	0	-	255	Speed from slow to fast

<b>37CH Mode( 37 Channels )</b>					
Number	Channel	DMX Value			Description
1	Pan	0	-	255	Pan 0 to 540 degree
2	Tilt 1	0	-	127	Tilt from 0-360 degree
		128		191	CW Infinity tilt Fast-Slow
		192		255	CCW infinity tilt slow-fast
3	Tilt 2	0	-	127	Tilt from 0-360 degree
		128		191	CW Infinity tilt Fast-Slow
		192		255	CCW infinity tilt slow-fast
4	Dimmer All	0	-	255	All dimmer 0 to 100%
5	Strobe	0	-	9	Blackout
		10	-	250	Strobe from slow to fast
		251	-	255	Open
6	Red1	0	-	255	Red1 Dimming 0-100%
7	Green1	0	-	255	Green1 Dimming 0-100%
8	Blue1	0	-	255	Blue1 Dimming 0-100%
9	White1	0	-	255	White1 Dimming 0-100%
10	Red2	0	-	255	Red2 Dimming 0-100%
11	Green2	0	-	255	Green2 Dimming 0-100%
12	Blue2	0	-	255	Blue2 Dimming 0-100%
13	White2	0	-	255	White2 Dimming 0-100%
14	Red3	0	-	255	Red3 Dimming 0-100%
15	Green3	0	-	255	Green3 Dimming 0-100%
16	Blue3	0	-	255	Blue3 Dimming 0-100%
17	White3	0	-	255	White3 Dimming 0-100%
18	Red4	0	-	255	Red4 Dimming 0-100%
19	Green4	0	-	255	Green4 Dimming 0-100%
20	Blue4	0	-	255	Blue4 Dimming 0-100%
21	White4	0	-	255	White4 Dimming 0-100%
22	Red5	0	-	255	Red5 Dimming 0-100%
23	Green5	0	-	255	Green5 Dimming 0-100%
24	Blue5	0	-	255	Blue5 Dimming 0-100%
25	White5	0	-	255	White5 Dimming 0-100%

26	Red6	0	-	255	Red6 Dimming 0-100%
27	Green6	0	-	255	Green6 Dimming 0-100%
28	Blue6	0	-	255	Blue6 Dimming 0-100%
29	White6	0	-	255	White6 Dimming 0-100%
30	Red7	0	-	255	Red7 Dimming 0-100%
31	Green7	0	-	255	Green7 Dimming 0-100%
32	Blue7	0	-	255	Blue7 Dimming 0-100%
33	White7	0	-	255	White7 Dimming 0-100%
34	Red8	0	-	255	Red8 Dimming 0-100%
35	Green8	0	-	255	Green8 Dimming 0-100%
36	Blue8	0	-	255	Blue8 Dimming 0-100%
37	White8	0	-	255	White8 Dimming 0-100%

## 6. DMX Connection

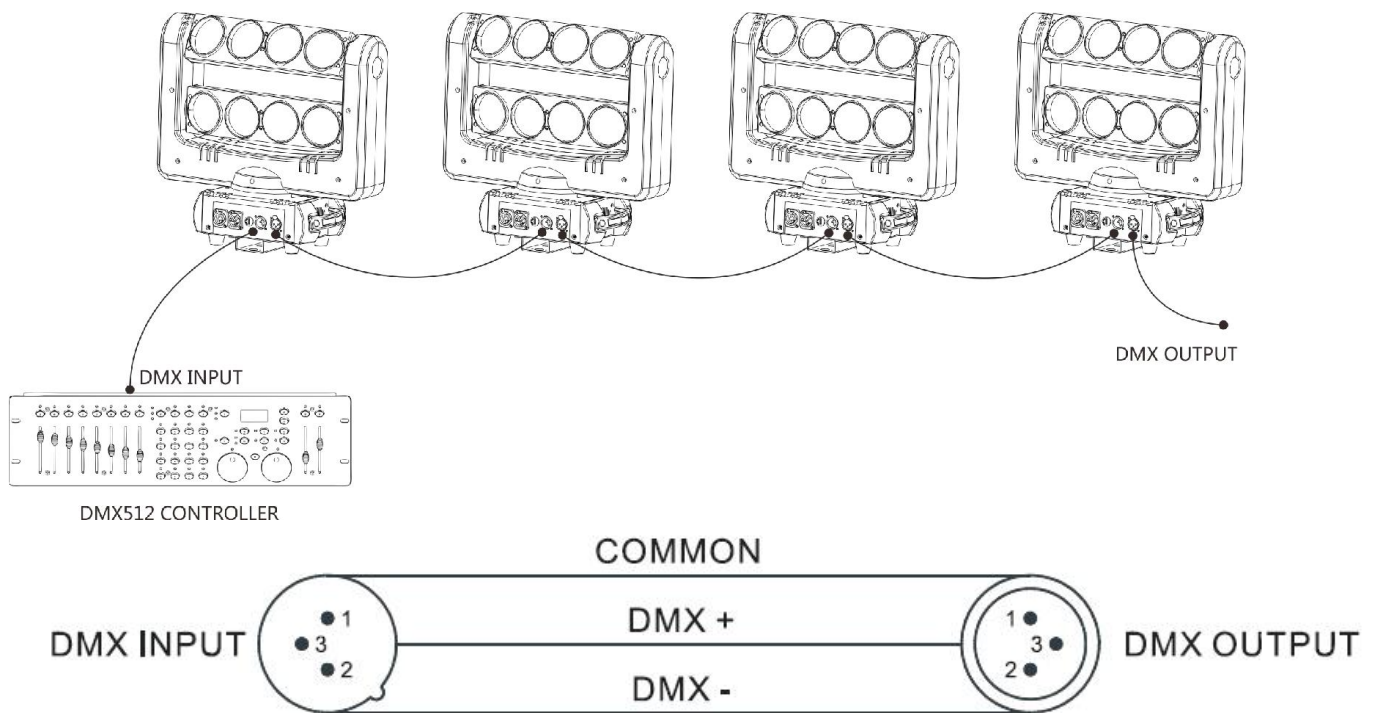

Termination reduces signal errors and to avoid signal transmission problems and interference. It is always advisable to connect a DMX terminal. (Resistance 120 ohm 1/4W) between pin2(DMX-) and pin3(DMX+) of the last fixture.



1. Connect the fixture together in a “daisy chain” by XLR plug cable from the output of the fixture to the input of the next fixture. The cable cannot be branched or split to a “Y” cable.

Inadequate or damaged cables, soldered joints or corroded connectors can easily distort the signal and shut down the system

2. The DMX output and input connectors are pass-through to maintain the DMX circuit when one of the units' power is disconnected.
3. At last fixture, the DMX cable has to be terminated with a terminator to reduce signal errors. Solder a 120-ohm 1/4W resistor between pin 2(DMX-) and pin 3(DMX+) into a 3-pin XLR-plug and plug it in the DMX-output of the last fixture.
4. Each lighting fixture needs to have an address set to receive the data sent by the controller. The address number is between 0-511 (usually 0 & 1 are equal to 1).
5. 3 pin XLR connectors are more popular than 5 pins XLR.  
3 pin XLR: Pin 1: GND, Pin 2: Negative signal (-), Pin 3: Positive signal (+)

## 7. Troubleshooting

Following are a few common problems that may occur during operation. Here are some suggestions for easy troubleshooting:

### A. The fixture does not work, no light

1. Check the connection of power and main fuse.
2. Measure the mains voltage on the main connector.

### B. Not responding to DMX controller

1. Check DMX connectors, cables to see if link properly.
2. Check the address settings and DMX polarity.
3. If you have intermittent DMX signal problems, check the pins on connectors or on PCB of the fixture or the previous one.
4. Try to use another DMX controller.
5. Check if the DMX cables run near or run alongside to high voltage cables that may cause damage or interference to DMX interface circuit.

### C. No response to the sound

1. Make sure the fixture does not receive DMX signal.

2. Check microphone to see if it is good by tapping the microphone.

#### **D. One of the channels is not working well**

1. The stepper motor might be damaged or the cable connected to the PCB is broken.

2. The motor's drive IC on the PCB might be out of condition.

## **8. Fixture Cleaning**

The cleaning must be carried out periodically to optimize light output. Cleaning frequency depends on the environment in which the fixture operates: moist, smoky or particularly dirty surrounding can cause greater accumulation of dirt on the fixture.

- Clean with soft cloth using normal glass cleaning fluid.
- Always dry the parts carefully.
- Clean the external optics at least every 30 days.